

D9-MC-MC-V1A

1. Description:

D9-MC-MC-V1A is a simple DB9 Male to DB9 Male crossover adapter breakout board. It brings all 9 pins of two DB9 Male connectors to screw terminal blocks and headers for easy testing, prototyping and breadboard connection. Modem to Modem (DCE to DCE) or Null Modem (DTE to DTE) mode can be selected with two jumpers. User can also use the two 5 pins headers on both sides of the breakout board to connect on breadboard or prototype PCB.

2. Features:

- All 10 pins (including shield) of two DB9 Male connectors brought out to headers and screw terminal blocks
- Selectable configuration Modem to Modem (DCE to DCE) or Null Modem (DTE to DTE)
- Various connecting method chosen by users.
- 4 X 2.0mm mounting holes
- 1.21"(30.8mm)X2.04"(51.8mm) board dimensions

3. Parts:

- 1) 1pc X D9-FMC-FMC-V1A PCB
- 2) 2pc X DB9 Male Connector
- 3) 2pc X 5pin 0.1"(2.54mm) spacing terminal block
- 4) 1pc X 14pin 0.1"(2.54mm) header
- 5) 2pc X 0.1"(2.54mm) jumper
- 6) 4pc X 4-40UNC diameter 8.3mm long screws

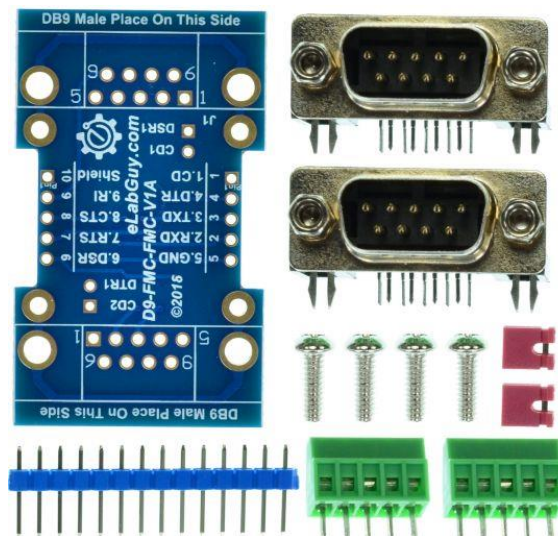

Figure 1: Parts inside the kit
(Note: the module is not assembled, user can decide which connector to use on the module.)

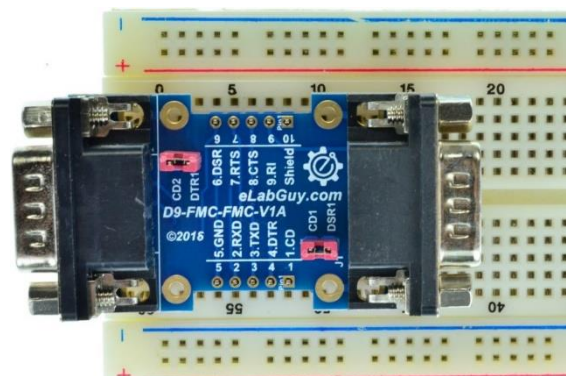

Figure 2: Example of connecting the D9-MC-MC-V1A on a proto PCB (Note: This picture only shows the pins spacing, actual use may not be used on a breadboard)



Figure 3: D9-MC-MC-V1A with headers

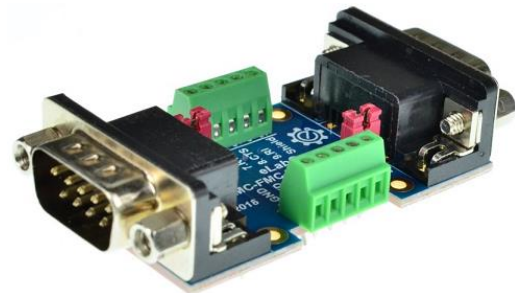

Figure 4: D9-MC-MC-V1A with terminal blocks

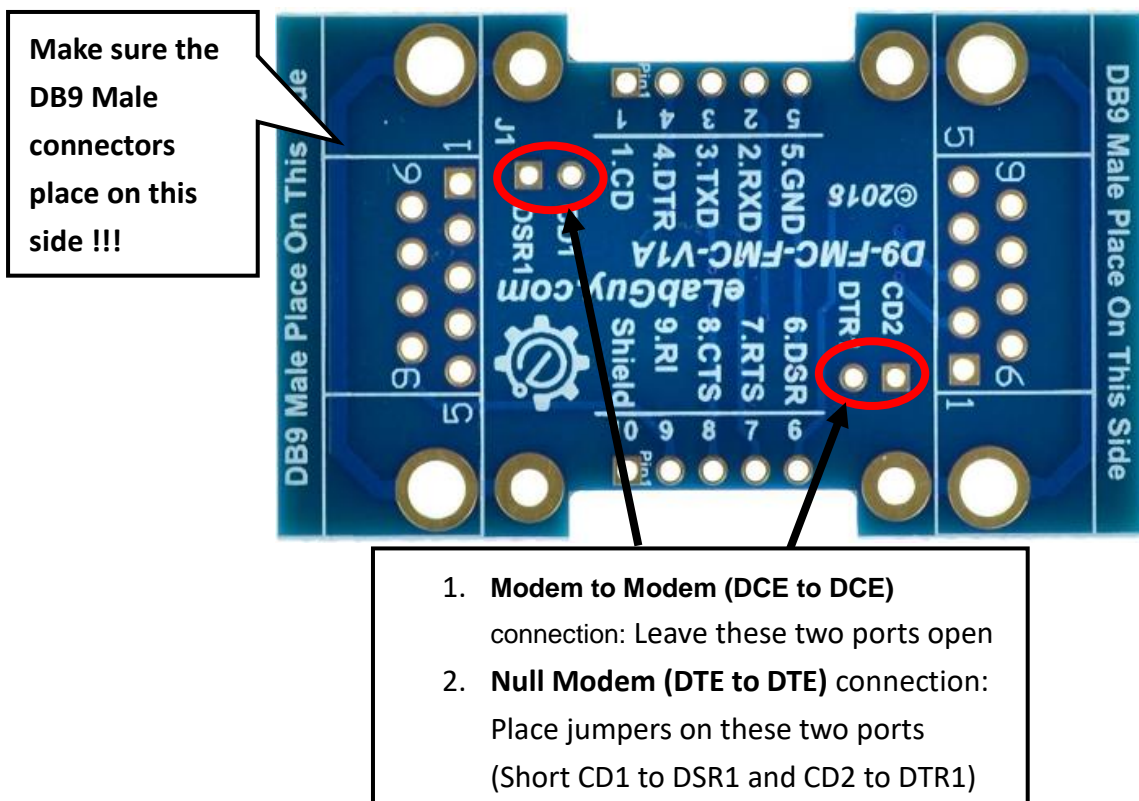

Figure 5: Modem to Modem (DCE to DCE) or Null Modem (DTE to DTE)

Related products from eLabGuy:



D9-FC-MC-V1A



D9-FC-FC-V1A



D9-MC-MC-V1A